

Density of Solids Lab

Name _____ Date _____ Period ___ Group ___

Problem: After calculating the density of a specific solid, like the ones in this lab, could this help you to identify which solid it is, if you are also given a list of known solids and their densities?

Hypothesis : _____

Variables: By the time you finish this experiment ,you will need to identify the different types of variables present in this investigation. Consult your notes for definitions of the types of variables.

Independent Variables: _____

Dependent Variables: _____

Controlled Variables: _____

Procedures: 1–Determine the density of the two cubes and the metal bar in the following way. Carefully measure the length, width, and height of the object and use this data to calculate the volume, using the formula, **volume=length x width x height**.

Measure the 3 sides of the cube and bar in the following way:

A–Pick one of the corners of each cube,and measure each of the three sides that meet at that corner to the nearest 0.01 cm.

(Refer to diagram)

The measurements in the diagram are just examples!

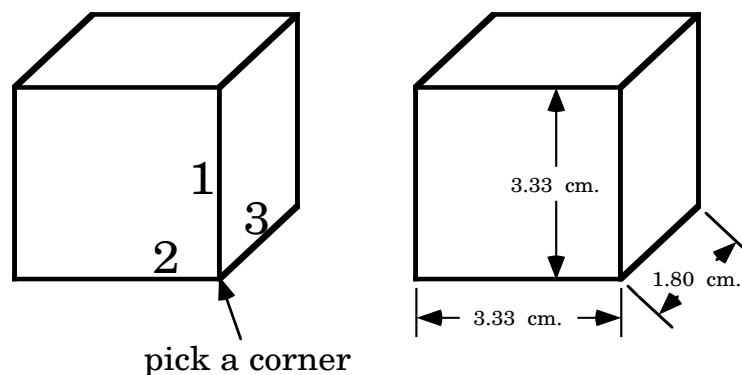

B–Pick one of the corners of the bar,and measure each of the three sides that meet at that corner to the nearest 0.01 cm.(**Do it the** same way as the cube)

C–Next carefully mass the objects to the nearest 0.01 g. Then, by using the formula,**density = mass ÷ volume**, calculate the density in grams / cm³.

2–Repeat the above steps using the second and then the third objects.

3–Finally, determine the mass and volume of a metal cylinder and then calculate its density from this data. **However**, to determine the volume of the metal cylinder, you will have to use the water displacement method, which your teacher will demonstrate.

Materials: Triple beam Balance,Plastic 50 ml Graduated cylinder, water,ruler, two cubes of different mass, metal bar, metal cylinder

Safety: General

Question 1 (To be answered **before** taking any measurements) Pick up each of the four objects. Rank **all four** objects in order, starting with the object you think is most dense, then the second most dense, and so on to the least dense object.

Observations

Record your measurements below for the **rectangular** shaped solids!

Object	Length of Side 1 to 0.01 cm	Length of Side 2 to 0.01 cm	Length of Side 3 to 0.01 cm	Volume in cm^3 to 0.01 cm^3	Mass in grams to 0.01g	Density in g/cm^3 to 0.01 g/cm^3
Light cube						
Heavy cube						
Metal Bar						

Record your measurements below for the **metal cylinder**!

Class Results

Volume of water to 0.1 cm^3	Volume of water <u>and</u> metal cylinder to 0.1 cm^3	Volume of just the metal cylinder to 0.1 cm^3	Mass of metal cylinder to 0.01g	Density in g/cm^3 to 0.1 g/cm^3

Group	Density of light cube	Density of heavy cube	Density of metal bar	Density of metal cylinder	Group	Density of light cube	Density of heavy cube	Density of metal bar	Density of metal cylinder
1					10				
2					11				
3					12				
4					13				
5					14				
6					15				
7					Range				
8					Mean				
9									

Question 2 (To be answered **after** taking all measurements **and** recording the class results) Now that you have more information to base your answer on, again rank **all four** objects in order, starting with the most dense object, then second most dense, and so on to the least dense object.

Question 3 Suppose someone in the class, had determined the volume of the metal cylinder by using the water displacement method, and then they measured it's mass without wiping dry the cylinder first. Explain what effect this would have on the density they calculate, compared with the actual density of the cylinder ?

Question 4 Examine the densities you and the class calculated for the metal cylinder. Using the density information supplied by your teacher as shown below, which substance is the metal cylinder most likely to be?

Substance X density is 2.7 g/cm^3

Substance Y density is 11.9 g/cm^3

Substance Z density is 7.8 g/cm^3

